

Load Ranger Cart

Transport Cart



Standard Features

- Can hold up to six Load Ranger wheel pads (with or without optional ramps) and one Load Ranger remote indicator case
- Two swivel, locking casters and two rigid casters
- Painted mild steel
- Integrated forklift channels
- Cam latch closures

Options/Accessories

- AC power strip for charging

Specifications

Warranty:

One-year limited

Part Number/Price

Part #	Description	Price
203078	Load Ranger transport cart for up to 6 Load Ranger wheel pads	Consult

Options/Accessories

Part #	Description	Price
Consult	AC power strip	Consult

Dimensions			
A	38.77 in (985 mm)	F	37.18 in (944 mm)
B	24.75 in (629 mm)	G	7.80 in (198 mm)
C	48.20 in (1,224 mm)	H	7.48 in (190 mm)
D	43.27 in (1,099 mm)	I	14.50 in (368 mm)
E	38.65 in (982 mm)	J	36.10 in (917 mm)

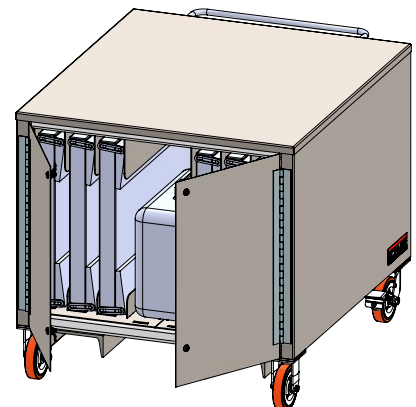
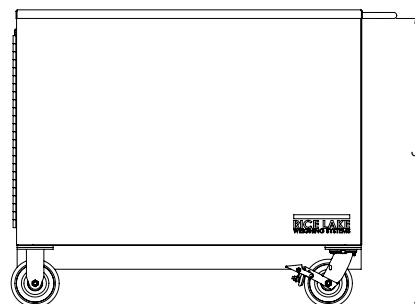
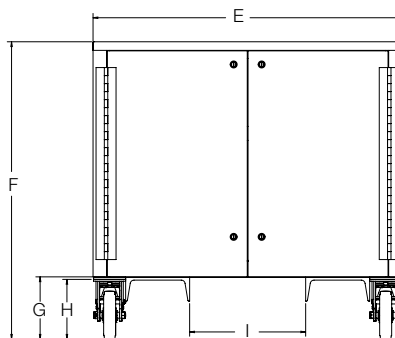
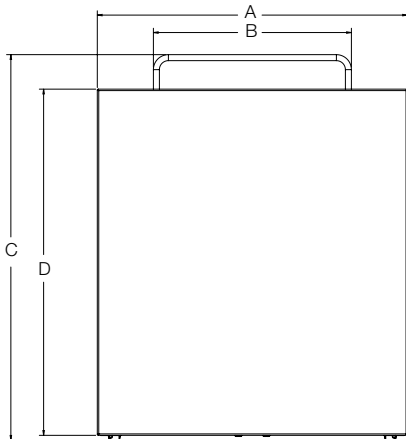

VEHICLE SCALES