

# RoughDeck® BDP Mild Steel

Barrel, Drum, Pallet Scale – Portable Model

## Specifications

### End Load Capacity:

1,000 lb: 100% full scale  
2,500 lb: 80% full scale

### Cable Length:

10 ft (3 m)

### Threaded Eyebolt:

Hole (1/2-13 NC) located in center of deck for easy lifting

### Warranty:

RoughDeck BDP weldment three years, load cells two years, all other components one year

### Approvals:

NTEP CC 03-060, Class III 2,500 d  
Measurement Canada AM-5578  
(500 kg) Class III 2,500 d  
(1,000 kg) Class III 2,000 d

## Standard Features

- Live siderails
- Top access foot adjustment holes
- Holes are 1/2-13 threaded for lifting scale
- Four adjustable stainless steel SUREFOOT™ support feet
- TuffSeal® JB4SS stainless steel, NEMA Type 4X junction box with signal trim card
- Treaded top plate
- Alloy steel load cells

## Approvals

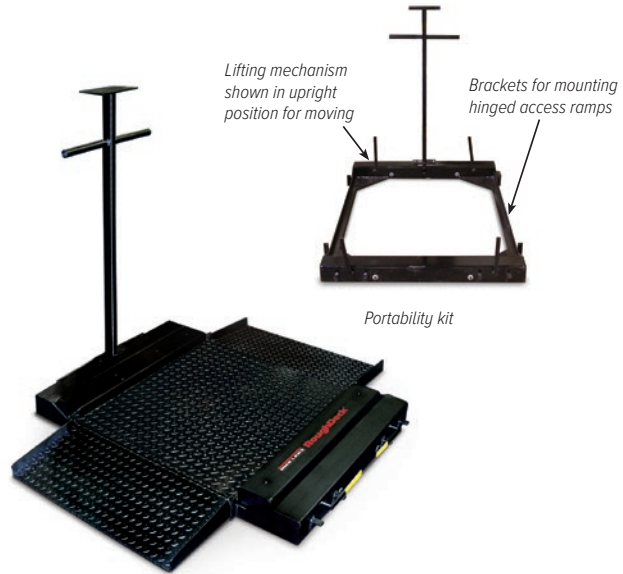

Scale shown with optional portability kit

## Part Number/Price

Part #	Size (W x L) Not Including Side Rails	Capacity (Canadian Approved Capacities)	Est. Weight	Price
77962	30 in x 31 in	1,000 lb (500 kg)	205 lb	Consult
77963	30 in x 31 in	2,500 lb (1,000 kg)	205 lb	Consult
77964	36 in x 37 in	1,000 lb (500 kg)	265 lb	Consult
77965	36 in x 37 in	2,500 lb (1,000 kg)	265 lb	Consult
<b>Portability Kits</b>				
Kits Include: Frame, two swivel and two fixed zinc plated steel NSF approved wheels (75 lb max. load capacity), indicator stand				
78021	For use with 30 in x 31 in scale		90 lb	Consult
78022	For use with 36 in x 37 in scale		100 lb	Consult
<b>RoughDeck BDP Portability Kit with conductive wheels for use with 882IS</b>				
199102	30 in x 31 in		25 lb	Consult
199103	36 in x 37 in		30 lb	Consult
Part #	Size (W x L)	Ramp Angle of Incline	Es. Weight	Price
<b>Hinged Access Ramps: For use with portability kit</b>				
78015	29.25 in x 12 in (sold individually)		8.7°	25 lb
78016	35.25 in x 12 in (sold individually)		8.7°	30 lb

## Options/Accessories

Part #	Description	Price
Consult	Mild steel deck with RL32018S IP66 stainless steel cFMus approved load cells and hardware	Consult
Consult	Mild steel deck with RL32218S-HE hermetically sealed IP69K stainless steel cFMus approved load cells and hardware	Consult

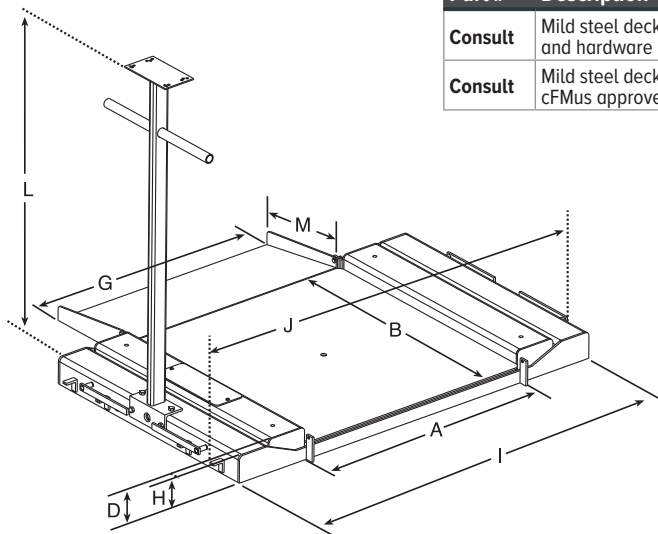

### Dimensions with portability frame & hinged access ramps

#### 30 in x 31 in models

A	30.0 in (762 mm)	I	49.25 in (1250.9 mm)
B	31.0 in (787.4 mm)	J	52.25 in (1,327.1 mm)
D	3.66 in (92.9 mm)	L	40.37 in (1,025.4 mm)
G	29.25 in (742.9 mm)	M	12.0 in (304.8 mm)
H	3.25 in (82.5 mm)		

#### 36 in x 37 in models

A	36.0 in (914.4 mm)	I	55.25 in (1,403.4 mm)
B	37.0 in (939.8 mm)	J	58.25 in (1,479.5 mm)
D	3.66 in (92.9 mm)	L	40.37 in (1,025.4 mm)
G	35.25 in (895.3 mm)	M	12.0 in (304.8 mm)
H	3.25 in (82.5 mm)		

Distance from floor to top of center weighing surface: 1.94 in (49.2 mm)

Distance from floor to bottom of weighing surface: 0.62 in (15.7 mm)