

# RL50219SS-TA

Mini Tank Weighing Module, Stainless Steel



RL50219SS-TA stainless (50lb-250lb)

Picture is a representation of actual product.

## Complete Kit Includes

- One JB4SS NEMA Type 4X stainless steel signal trim junction box
- Three or four RL50219SS cantilever beam load cells (50 to 250 lb models)
- Three or four stainless steel single-ended beam load cells (500 lb models)
- Three or four neoprene isolation/compression mounts
- 25 ft of hostile environment EL147HE SURVIVOR® load cell cable

## Standard Features

- Stainless steel modules
- Lower weighing ranges from 50 to 500 lb per module
- Environmentally protected load cells
- Neoprene isolation/compression mounts allow for minor misalignment, thermal expansion and shock absorption
- Overload stop for 500 lb modules provides durability

## Applications

- Small tanks and hoppers
- Conveyor/in-motion weighing
- Small platform scales where minor shock loading may occur

## Order Information

Load Rating (Per Module)	Part #	Price
<b>Single Module (Includes Load Cell)</b>		
50 lb	196829	Consult
75 lb	196830	Consult
100 lb	196831	Consult
150 lb	196832	Consult
250 lb	196833	Consult
500 lb	17954	Consult
<b>3-Module Kit</b>		
50 lb	196840	Consult
75 lb	196841	Consult
100 lb	196842	Consult
150 lb	196843	Consult
250 lb	196844	Consult
500 lb	30394	Consult
<b>4-Module Kit</b>		
50 lb	196845	Consult
75 lb	197015	Consult
100 lb	196846	Consult
150 lb	196848	Consult
250 lb	196849	Consult
500 lb	30393	Consult

WEIGH MODULES

# RL50219SS-TA

Mini Tank Weighing Module, Stainless Steel

## Dimensions

Rated Capacity	C	C1	H	H1	L	L1	L2	W	W1	W2	W3
<b>lb/in</b>											
50 to 250	0.34	-	3.13	0.50	4.00	3.25	2.38	3.88	3.00	2.25	-
500	0.44	0.56	3.88	0.50	6.00	4.00	3.38	5.50	4.00	3.00	4.13

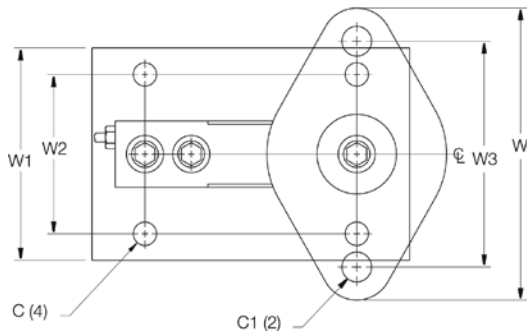

500lb

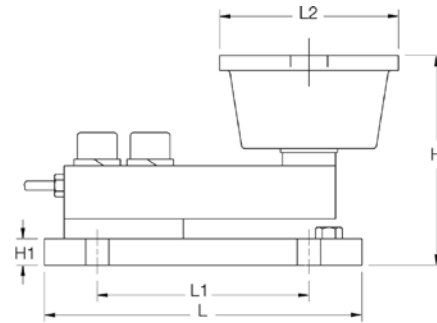

WEIGH MODULES

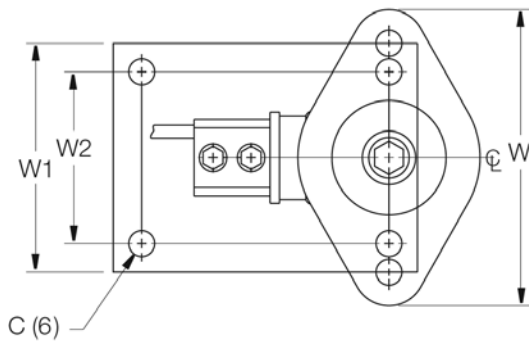

50-250lb

