

# Ready-n-Weigh Bench Scale System

CW-90XB Bench Scale and 482/482 Plus Indicator Package

BENCH SCALES



## Approvals



## Standard Features

- Package includes scale with IP69K stainless steel hermetically sealed load cell with an indicator and 12-inch
- Factory calibrated with indicator setup and configured for 5,000 divisions
- Scale includes rubber feet to provide exceptional traction and avoid scratching surfaces along with removable top cover for ease of cleaning
- AC power 100 to 240 VAC
- LCD backlit display suitable for a variety of environments
- Battery backed time and date
- Standard RS-232 serial ports for connecting to a variety of peripherals

Dimensions			
10 × 10 in			
A	19.50 in	E	9.25 in
B	10.25 in	F	4.25 in
C	14.53 in	G	10.25 in
D	13.25 in		

Note: 1 in = 25.4 mm

Dimensions			
12 × 12 in			
A	19.50 in	E	9.25 in
B	12.25 in	F	4.25 in
C	16.53 in	G	12.25 in
D	13.25 in		

Note: 1 in = 25.4 mm

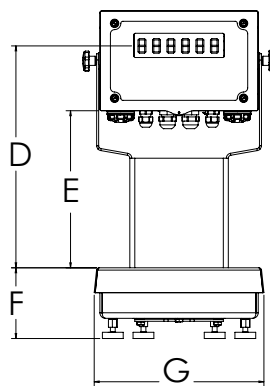
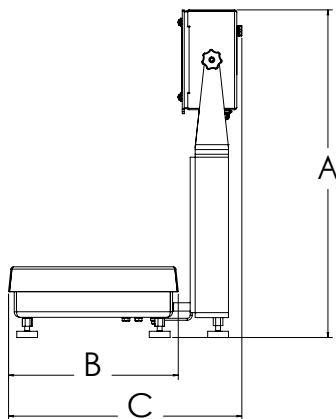

CW-90XB with 482 indicator

## Specifications

**Load Cell, NTEP Certified:**  
IP69K stainless steel and hermetically sealed

**Scale Construction:**  
304 stainless steel

**Maximum Overload:**  
180% to 200% depending on capacity

**Overload Protection:**  
Five-point, independently adjusted

**Scale Frame:**  
AISI304L, straight line finish, Ra = 45 +/- 10

**Scale Cover:**  
AISI304L, straight line finish, Ra = 45 +/- 10

**Cable Length:**  
34 in

**Compensated Temperature Range:**  
14 °F to 104 °F (-10 °C to 40 °C)

**Approvals:**  
NTEP CC 95-072, Class III 5,000 d  
Measurement Canada AM-5082  
Load cell is FM approved

**Warranty:**  
Three-year limited (includes water ingress)

## 482/482 Plus Specifications

**Communication Ports:**  
Com 1: RS-232 full duplex  
Com 2: RS-232 full duplex or 20 mA simplex, continuous  
Both ports 1200, 2400, 4800, 9600, 19200, 38400 baud seven or eight data bits, even, odd or no parity

**Display:**  
LCD backlit display, transmissive/transflective  
0.8 in (20 mm), six-digit, seven-segment

**Status Annunciators:**  
Gross, net, center of zero, standstill, lb, kg, tare, preset tare

**Keys/Buttons:**  
Flat membrane panel, embossed keys, tactile feel

**Rating/Material:**  
Enclosure: NEMA Type 4X/IP66, heavy-gauge stainless steel

**Approvals:**  
NTEP CC 12-123  
Measurement Canada AM-5892C  
CE Marked  
cULus Listed

**Warranty:**  
Two-year limited

# Ready-n-Weigh Bench Scale System

CW-90XB Bench Scale and 482/482 Plus Indicator Package

## CW-90XB with 482 Package

Part #	Platform Capacity	Dimensions (L × W × H)	Est. Weight	Price
<b>115 VAC, LCD, US Plug-Type B</b>				
201533	5 lb (2.5 kg)	10 × 10 × 4.25 in	24 lb	Consult
201534	10 lb (5 kg)	10 × 10 × 4.25 in	24 lb	Consult
201535	25 lb (10 kg)	10 × 10 × 4.25 in	24 lb	Consult
201536	25 lb (10 kg)	12 × 12 × 4.25 in	27 lb	Consult
201537	50 lb (25 kg)	12 × 12 × 4.25 in	27 lb	Consult
201538	100 lb (50 kg)	12 × 12 × 4.25 in	27 lb	Consult
<b>90-264 VAC, LCD, Euro Plug-Type E</b>				
201546	5 lb (2.5 kg)	10 × 10 × 4.25 in	24 lb	Consult
201547	10 lb (5 kg)	10 × 10 × 4.25 in	24 lb	Consult
201548	25 lb (10 kg)	10 × 10 × 4.25 in	24 lb	Consult
201549	25 lb (10 kg)	12 × 12 × 4.25 in	27 lb	Consult
201550	50 lb (25 kg)	12 × 12 × 4.25 in	27 lb	Consult
201551	100 lb (50 kg)	12 × 12 × 4.25 in	27 lb	Consult

## CW-90XB with 482 Plus Package

Part #	Platform Capacity	Dimensions (L × W × H)	Est. Weight	Price
<b>115 VAC, LCD, Numeric, US Plug-Type B</b>				
201539	5 lb (2.5 kg)	10 × 10 × 4.25 in	24 lb	Consult
201541	10 lb (5 kg)	10 × 10 × 4.25 in	24 lb	Consult
201542	25 lb (10 kg)	10 × 10 × 4.25 in	24 lb	Consult
201543	25 lb (10 kg)	12 × 12 × 4.25 in	27 lb	Consult
201544	50 lb (25 kg)	12 × 12 × 4.25 in	27 lb	Consult
201545	100 lb (50 kg)	12 × 12 × 4.25 in	27 lb	Consult
<b>90-264 VAC, LCD, Numeric, Euro Plug-Type E</b>				
201552	5 lb (2.5 kg)	10 × 10 × 4.25 in	24 lb	Consult
201553	10 lb (5 kg)	10 × 10 × 4.25 in	24 lb	Consult
201554	25 lb (10 kg)	10 × 10 × 4.25 in	24 lb	Consult
201555	25 lb (10 kg)	12 × 12 × 4.25 in	27 lb	Consult
201556	50 lb (25 kg)	12 × 12 × 4.25 in	27 lb	Consult
201557	100 lb (50 kg)	12 × 12 × 4.25 in	27 lb	Consult



\* US plug (NA) - Type B



\*\* Euro Plug - Type E