

Ready-n-Weigh Bench Scale System

CW-90B Bench Scale and 380 Indicator Package

BENCH SCALES



Approvals



CW-90B with 380 Package

Part #	Capacity	Dimensions (L x W x H)	Est. Weight	Price
208528	5 lb (2.5 kg)	10 x 10 x 4.25 in	24 lb	Consult
208529	10 lb (5 kg)	10 x 10 x 4.25 in	24 lb	Consult
208530	25 lb (10 kg)	10 x 10 x 4.25 in	24 lb	Consult
208531	25 lb (10 kg)	12 x 12 x 4.25 in	27 lb	Consult
208532	50 lb (25 kg)	12 x 12 x 4.25 in	27 lb	Consult
208533	100 lb (50 kg)	12 x 12 x 4.25 in	27 lb	Consult

Options/Accessories

Part #	Description	Price
206433†	External AC adaptor	Consult
204258	Real-time clock module	Consult



† US plug (NA) - Type A

Dimensions

10 x 10 in

A	19.68 in	E	9.43 in
B	10.20 in	F	4.25 in
C	14.02 in	G	10.20 in
D	13.36 in		

Note: 1 in = 25.4 mm

Dimensions

12 x 12 in

A	19.56 in	E	9.30 in
B	12.38 in	F	4.25 in
C	16.10 in	G	12.35 in
D	13.23 in		

Note: 1 in = 25.4 mm

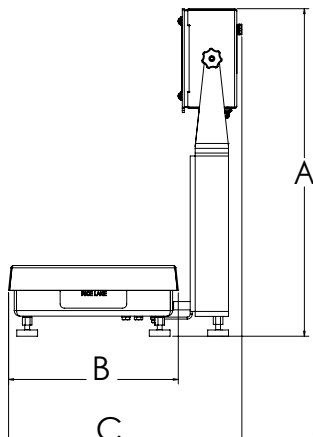

CW-90B with 380 indicator

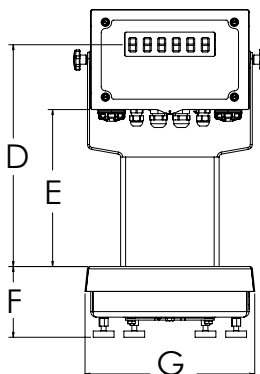

Standard Features

- Package includes scale with IP67 aluminum environmentally sealed load cell with an indicator and 12-inch column
- Factory calibrated with indicator setup and configured for 5,000 divisions
- Scale includes rubber feet to provide exceptional traction and avoid scratching surfaces along with removable top cover for ease of cleaning
- Standard RS-232 serial port for connecting to a variety of peripherals
- Powered by four alkaline C-cell batteries (not included) or external AC adaptor (not included)

CW-90B Specifications

Load Cell, NTEP Certified:

IP67 aluminum, environmentally sealed

Scale Construction:

304 stainless steel

Maximum Overload:

180% to 200% depending on capacity

Overload Protection:

Five-point, independently adjusted

Scale Frame:

AISI304L, straight line finish, Ra = 45 +/- 10

Scale Cover:

AISI304L, straight line finish, Ra = 45 +/- 10

Cable Length:

34 in

Compensated Temperature Range:

14 °F to 104 °F (-10 °C to 40 °C)

Approvals:

NTEP CC 95-072, Class III 5,000 d

Measurement Canada AM-5082

Load cell is cFmus approved

Warranty:

Two-year limited

380 Specifications

Power:

Batteries: 4 alkaline C-cell

Optional: 115/230 VAC to 12 VDC adaptor

Battery Life:

45 hours with 4 x 350 ohm load cells, low backlight

Communication Ports:

One RS-232 (three-wire)

One USB 2.0

Display:

Six 1 in (25 mm) tall, LCD digits

Status Annunciators:

g, lb, t, tn, kg, oz, battery level, PT, LT, gross, zero, unstable, net

Keys/Buttons:

5 tactile buttons

Rating/Material:

Enclosure: IP66, 304 Stainless steel

Approvals:

NTEP CC 21-051

Measurement Canada AM-6184

CE Marked

cULus Listed

Warranty:

Two-year limited