

SINGLE POINT
PW15AH

Stainless Steel, Hermetically Sealed, NTEP Certified 1:5,000 Class III Single Cell, OIML C3, IP69K

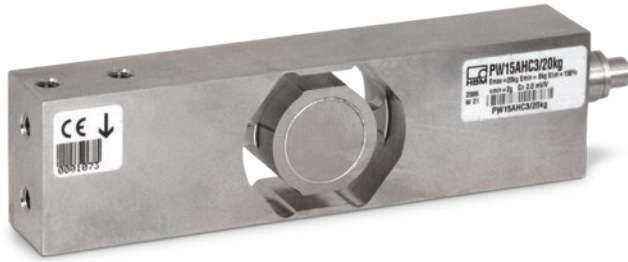

Picture is a representation of actual product.

Approvals



Order Information

Load Rating	Part #	Est. Weight	Price
10 kg	101915	3 lb	Consult
20 kg	101916	3 lb	Consult
50 kg	101917	3 lb	Consult
100 kg	101918	3 lb	Consult

Dimensions

Rated Capacity	B	E	F	G	H	I	J
kg/mm							
10 to 100	19.0	25.0	75.0	100.0	17.5	40.0	150.0

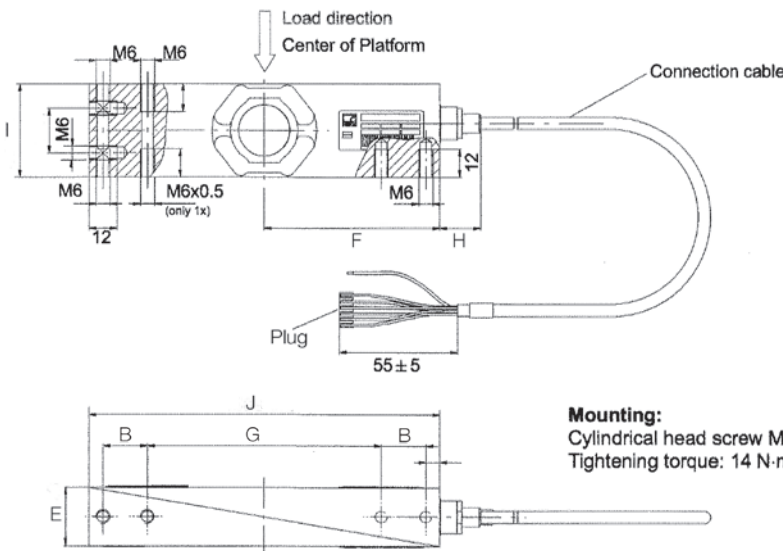

Interchangeable Products

RICE LAKE WEIGHING SYSTEMS
RLPWM15.....page 154
 FLINTEC®
PC4.....page 218

Specifications

- Full Scale Output:**
2.0 mV/V
- Output Resistance:**
350 (± 10) ohm
- Input Resistance:**
380 (± 15) ohm
- Material/Finish:**
Stainless steel
- Temperature:**
Compensated range
14 °F to 104 °F (-10 °C to 40 °C)
Operating range
0 °F to 150 °F (-18 °C to 65 °C)
- Seal Type:**
Hermetically sealed, IP69K
- Safe Overload:**
150% full scale
- Rated Excitation:**
5 to 10 VDC (15 V maximum)
- Combined Error:**
0.02% full scale
- Insulation Resistance:**
1,000 megohm
- Cable Length:**
10 ft
- Cable Diameter:**
0.212 in PVC jacket
- Cable Color Code:**
Blue +Excitation
Black -Excitation
White +Signal
Red -Signal
Green +Sense
Grey -Sense
- Warranty:**
One-year limited
- Approvals:**
NTEP
OIML
FM

HBK