

Picture is a representation of actual product

Approvals

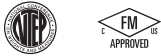

Order Information

Load Rating	Part #	Est. Weight	Price
NTEP Certified			
100 lb	21447	3 lb	Consult
250 lb	21448	3 lb	Consult
500 lb	21449	3 lb	Consult
1,000 lb	21450	3 lb	Consult
2,500 lb	21451	4 lb	Consult
5,000 lb	21452	6 lb	Consult
Non-NTEP Certified			
10,000 lb	17032	6 lb	Consult

Dimensions

Rated Capacity	A	C	D	E
100 to 250 lb/in	3/8-24 UNF	0.94	2.48	3.32
500	1/2-20 UNF	0.71	2.44	3.50
1,000	1/2-20 UNF	0.71	2.44	3.50
2,500	1/2-20 UNF	0.95	2.44	3.75
5,000 to 10,000	1-14 UNS	1.44	2.44	4.75

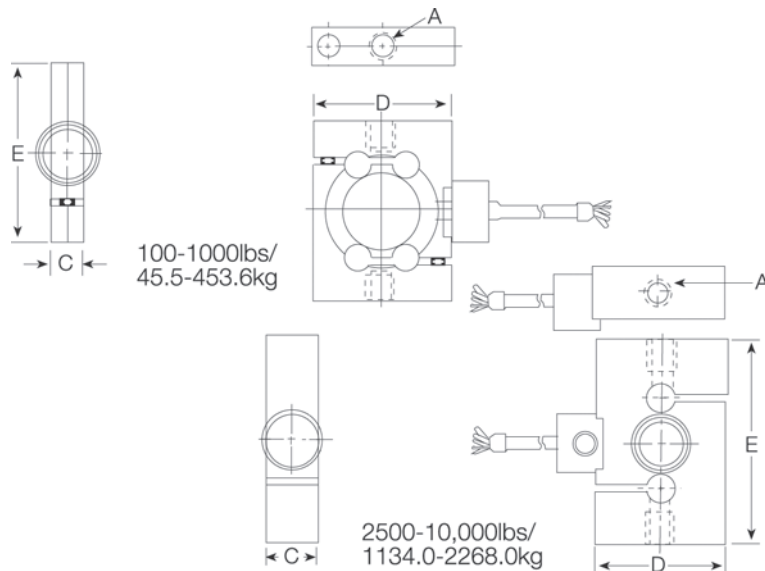

Weigh Module Available

RICE LAKE WEIGHING SYSTEMS
ITCM Isolated Tension Cell Mount..... page 28

Specifications

- Full Scale Output:**
3.0 mV/V
- Output Resistance:**
350 (± 3.5) ohm
- Input Resistance:**
350 (± 3.5) ohm
- Material/Finish:**
Stainless steel
- Temperature:**
Compensated range
14 °F to 104 °F (-10 °C to 40 °C)
Operating range
0 °F to 150 °F (-18 °C to 65 °C)
- Seal Type:**
Welded-seal, IP67
- Safe Overload:**
150% full scale
- Rated Excitation:**
5 to 10 VDC (15 V maximum)
- Combined Error:**
0.03% full scale
- Non Repeatability:**
0.01% full scale
- Insulation Resistance:**
5,000 megohm
- Cable Length:**
30 ft
- Cable Color Code:**
Green +Excitation
Black -Excitation
White +Signal
Red -Signal
- Warranty:**
One-year limited
- Approvals:**
cFMus
NTEP