

Picture is a representation of actual product

Approvals

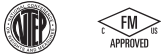

Order Information

Load Rating	Part #	Est. Weight	Price
50,000 lb	69489	17 lb	Consult
65,000 lb	69490	17 lb	Consult
100,000 lb	124390	17 lb	Consult

Dimensions

Rated Capacity	A	D	F	G	H	J	K	L	P
lb/in									
50,000 to 100,000	10.25	1.00	1.94	2.40	4.25	8.50	1.00	2.06	2.94

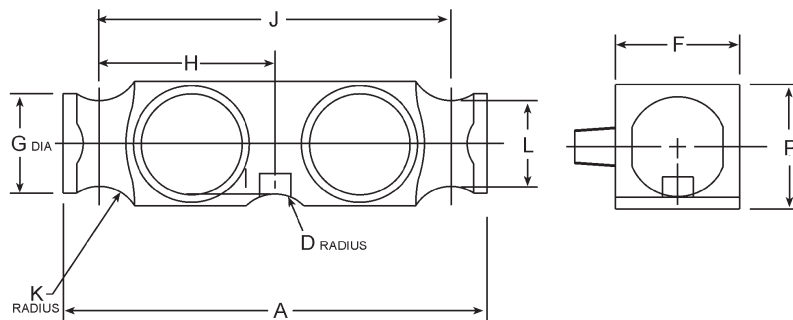

Interchangeable Products

NV TECHNOLOGY®
BLC-2-XX-N
 THURMAN®
10088970A-50K

Specifications

- Full Scale Output:**
3.0 mV/V
- Output Resistance:**
700 (± 3.5) ohm
- Input Resistance:**
700 (± 3.5) ohm
- Material/Finish:**
Stainless steel
- Temperature:**
Compensated range
14 °F to 104 °F (-10 °C to 40 °C)
Operating range
0 °F to 150 °F (-18 °C to 65 °C)
- Seal Type:**
Environmentally sealed, IP67
- Safe Overload:**
150% full scale
- Safe Sideload:**
100% full scale
- Rated Excitation:**
5 to 10 VDC (15 V maximum)
- Non-repeatability:**
0.01% full scale
- Combined Error:**
0.02% full scale
- Insulation Resistance:**
5,000 megohm
- Cable Length:**
30 ft
- Cable Diameter:**
0.295 in
Polyurethane jacket
- Cable Color Code:**
Red +Excitation
Black -Excitation
Green +Signal
White -Signal
- Warranty:**
One-year limited
- Approvals:**
cMus
NTEP