

Picture is a representation of actual product

Approvals



Available upon request

Order Information

Load Rating	Part #	Est. Weight	Price
10 kg	156361	3 lb	Consult
15 kg	156362	3 lb	Consult
20 kg	156363	3 lb	Consult
30 kg	156364	3 lb	Consult
50 kg	156365	3 lb	Consult
100 kg	156367	3 lb	Consult
150 kg	157809	3 lb	Consult

Metric threads available as an option

Dimensions

Rated Capacity	A	B	C	D	E	F	G	H	T	T1
kg/mm										
10 to 150	150.0	19.1	39.0	34.0	125.0	115.0	40.0	25.4	1/4-20 UNC	1/4-28 UNF

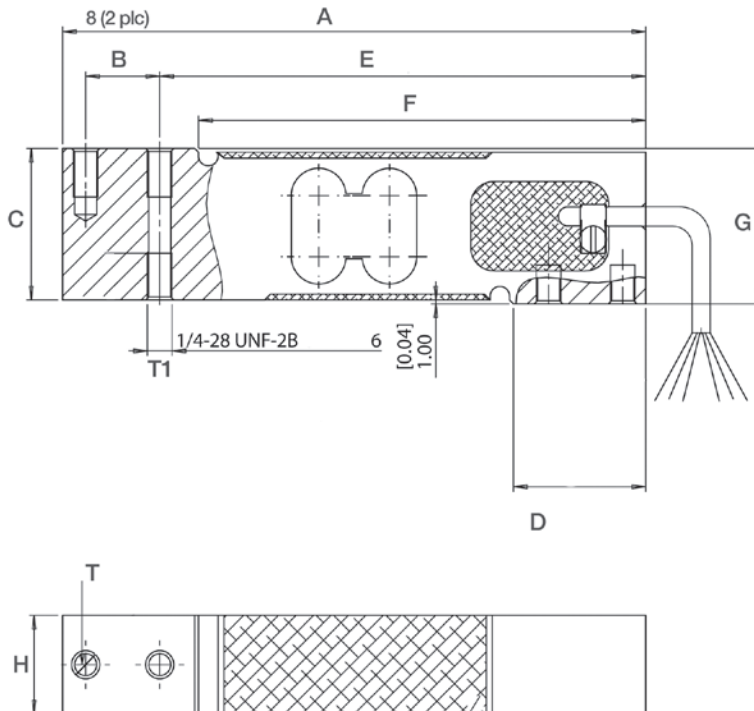

Interchangeable Products

RICE LAKE WEIGHING SYSTEMS

RLPWM15..... page 154

HBM®*

PW15..... page 229

*Color code is different

Specifications

Full Scale Output:

2.0 mV/V

Output Resistance:

351 (± 5.0) ohm

Input Resistance:

385 (± 10) ohm

Material/Finish:

Stainless steel

Temperature:

Compensated range

14 °F to 104 °F (-10 °C to 40 °C)

Operating range

0 °F to 150 °F (-18 °C to 65 °C)

Seal Type:

Environmentally sealed, IP66

Safe Overload:

150% full scale

Rated Excitation:

5 to 10 VDC nominal (15 V maximum)

Combined Error:

0.02% full scale

Deflection at Capacity:

0.015 in

Insulation Resistance:

2,000 megohm

Cable Length:

10 ft

Cable Diameter:

0.200 in PVC Jacket

Platform Size:

16 × 16 in

Cable Color Code:

Green +Excitation

Black -Excitation

Red +Signal

White -Signal

Blue +Sense

Brown -Sense

Warranty:

One-year limited

Approvals:

cFMus

NTEP

OIML (Available upon request)