

# 480/482 Legend® Series

Digital Weight Indicator

INDICATORS /  
CONTROLLERS



## Specifications

### Power:

Line voltages: 100 to 240 VAC  
Frequency: 50/60 Hz  
DC voltages: n/a

### Power consumption:

8 W

### Excitation Voltage:

5 VDC, 8 × 350 ohm or 16 × 700 ohm load cells

### Analog Signal Input Range:

±7mV/V

### Analog Signal Sensitivity:

0.1 μV/graduation minimum,  
0.5 μV/graduation recommended

### A/D Sample Rate:

5, 10, 20, 40 Hz, software selectable

### Resolution:

Internal: 523,000 counts  
Display: 100,000

### System Linearity:

Within 0.01% of full scale

### Digital I/O:

Optional 2 or 4 inputs  
4 or 8 dry-contact relays

### Communication Ports:

Com 1: RS-232 full duplex  
Com 2: RS-232 full duplex or 20 mA simplex, continuous  
Both ports 1200, 2400, 4800, 9600, 19200, 38400 baud seven or eight data bits, even, odd or no parity

### (Optional) Analog Output:

16-bit resolution, voltage output 0-10 VDC, current output 0-20 mA / 4-20 mA

### (Optional) Relay Board:

Two opto-isolated, 5 to 24 VDC, active high inputs  
Primary keys, pseudo functions, batching functions  
(4) 30 VDC, 2 amp dry-contact relays

### Annunciators:

Gross, net, center of zero, standstill, lb, kg, tare, preset tare

### Display:

**480/480 Plus:** LED display  
0.8 in (20 mm), six-digit, seven-segment  
**482/482 Plus:** LCD backlit display,  
transmissive/transflective  
0.8 in (20 mm), six-digit, seven-segment

### Keys/Buttons:

Flat membrane panel, embossed keys, tactile feel

### Temperature Range:

Certified: 14 °F to 104 °F (-10 °C to 40 °C)  
Operating: 14 °F to 122 °F (-10 °C to 50 °C)

### Rating/Material:

NEMA Type 4X/IP66  
Stainless steel

### Weight:

6.4 lb (2.9 kg)

### Warranty:

Two-year limited

### EMC Immunity:

EN 50082 Part 2 IEC EN  
61000-4-2, 3, 4, 5, 6, 8, and 11

### Approvals:

NTEP CC 12-123, Class III/III, 10,000d  
Measurement Canada AM-5892C  
OIML R76/2006-NL1-15.24  
EU Test Certificate TC8322  
CE Marked  
cULus  
UKCA

## Approvals



## Standard Features

- LED display (480)
- LCD backlit display (482)
- Time and date, battery backed
- Local/remote operation
- Numeric keypad (480 Plus/482 Plus)
- Keyed entries for setpoint values (480 Plus/482 Plus)
- Two independent serial ports
- NEMA Type 4X/IP66 stainless steel washdown enclosure
- Programmable ticket formats for gross, net, accumulator and setpoints
- Five continuous stream formats
- Adapter filter or rolling average filter
- Operator functions through menu for audit trail, preset tare, unit ID, accumulator, time and date, setpoints, communications and print formats
- Eight setpoints, sequenced batch engine
- Configurable with Revolution® software

## Dimensions

A	9.50 in (241 mm)	D	3.65 in (92 mm)	G	6.00 in (152 mm)
B	10.00 in (254 mm)	E	2.75 in (70 mm)	H	3.75 in (95 mm)
C	11.00 in (279 mm)	F	7.00 in (178 mm)		

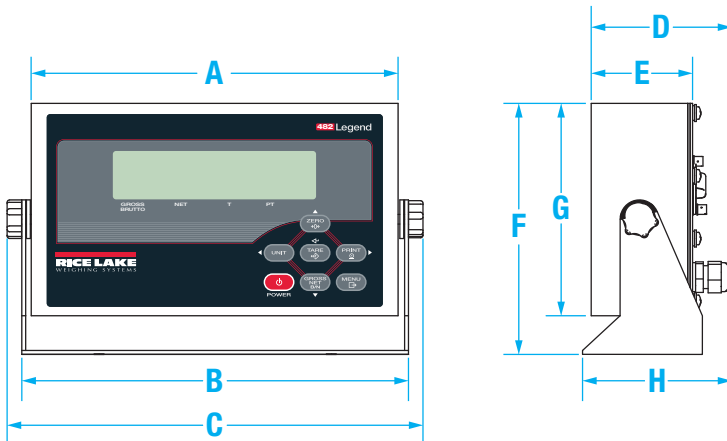

# 480/482 Legend® Series

Digital Weight Indicator

INDICATORS /  
CONTROLLERS

## Part Number/Price

Part #	Description	Est. Weight	Price
<b>480 Indicator 115 VAC †</b>			
126564 †	480 LED	8 lb	Consult
130338 †	480 LED with analog output	8 lb	Consult
<b>480 Indicator 90 to 264 VAC ††</b>			
126565 ††	480 LED	8 lb	Consult
130339 ††	480 LED with analog output	8 lb	Consult
<b>480 Plus Indicator 115 VAC †</b>			
164588 †	480 Plus LED	8 lb	Consult
164589 †	480 Plus LED with analog output	8 lb	Consult
164590 †	480 Plus LED with relay output	8 lb	Consult
<b>480 Plus Indicator 90 to 264 VAC ††</b>			
164591 ††	480 Plus LED	8 lb	Consult
164592 ††	480 Plus LED with analog output	8 lb	Consult
164593 ††	480 Plus LED with relay output	8 lb	Consult
<b>482 Indicator 115 VAC †</b>			
164581 †	482 LCD	8 lb	Consult
<b>482 Indicator 90 to 264 VAC ††</b>			
164672 ††	482 LCD	8 lb	Consult
<b>482 Plus Indicator 115 VAC †</b>			
164584 †	482 Plus LCD	8 lb	Consult
<b>482 Plus Indicator 90 to 264 VAC ††</b>			
164673 ††	482 Plus LCD	8 lb	Consult

## Options/Accessories

Part #	Description	Price
131340	Mounting bracket for option boards	Consult
131341	Analog output, 0-10 VDC, 4-20mA (requires 131340)	Consult
131342	Relay board, two digital inputs, four dry contact outputs (requires 131340)	Consult
165379	Flash update cable	Consult
151100	A/D sealing kit, used with audit trail tracking	Consult
151099	Panel mount bezel (not NEMA Type rated)	Consult
83564	Clear protective overlay (package of five)	Consult
119201	Installation manual (480 indicator)	Consult
165124	Installation manual (482 indicator)	Consult
<b>Primary Replacement Components</b>		
131345	Overlay, 480 six-key, red window	Consult
159612	Overlay, 480 Plus with numeric keys, red window	Consult
131346	Display board, LED	Consult
161048	Overlay, 482 six-key, green window	Consult
161049	Overlay, 482 Plus with numeric keys, green window	Consult
153776	Display board, LCD	Consult
131316	Power supply, 85-265 VAC	Consult
131318	CPU board	Consult
131319	A/D board	Consult

\* Revolution can be downloaded for free at [www.ricelake.com](http://www.ricelake.com)

To have your option factory installed, please specify when placing your order.



† US plug (NA) - Type B



†† Euro Plug - Type E