



## Specifications

### Power:

Line voltages: 115 to 230 VAC  
Frequency: 50 /60 Hz

### Power Consumption:

1.5 A at 115 VAC (8 W)  
0.75 A at 230 VAC (8 W)

### Excitation Voltage:

+5 VDC 8 × 350 ohm or 16 × 700 ohm load cells

### Analog Signal Input Range:

-0.5 mV/V to 4.5 mV/V

### Analog Signal Sensitivity:

0.3 uV/graduation minimum  
1.5 uV/graduation recommended

### A/D Sample Rate:

7.5 to 960 Hz software selectable

### Resolution:

Display: 100,000 counts

### System Linearity:

± 0.01% full scale

### Digital I/O:

Four channels on CPU board

### Circuit Protection:

RFI, EMI, ESD protection

### Annunciators:

Designators for percent, kg, gm, lb, oz, center of zero, G/B, N, T, PT, neg, motion

### Display:

Large 0.8 in 14-segment, six-digit high-intensity red LED display

### Keys/Buttons:

Membrane keypad, 23 keys with international symbols

### Temperature Range:

Certified: 14 °F to 104 °F (-10 °C to 40 °C)

### Rating/Material:

IP66, 304 stainless steel

### Warranty:

Two-year limited

### Approvals:

NTEP CC 08-092, Class III/IIIL 10,000d  
Measurement Canada AM-5710  
OIML R76/2006-GBI-10.02  
T C 11569  
cULus Listed  
CE marked

## Approvals



## Dimensions

A	9.5 in (241 mm)
B	10.02 in (255 mm)
C	11.24 in (285 mm)
D	3.12 in (79 mm)
E	6.00 in (152 mm)
F	8.57 in (218 mm)
G	3.75 in (95 mm)
H	4.00 in (102 mm)

## Standard Features

- PreVent™ breather vent
- Storage for up to 50 IDs
- Unit of measure: kg, gm, lb, oz, lb/oz
- LED display
- Two full duplex serial ports
- Configurable print formats
- Audit trail tracking
- Optional communications: Ethernet, USB or fiber-optic
- Four configurable digital I/O
- Reflash memory to upgrade firmware
- Auto print capability
- Battery backed up time and date
- Accumulator
- Membrane keypad consisting of zero, units, print, tare, over, under, ID, target, 0 to 9, clear, decimal, enter, menu, power

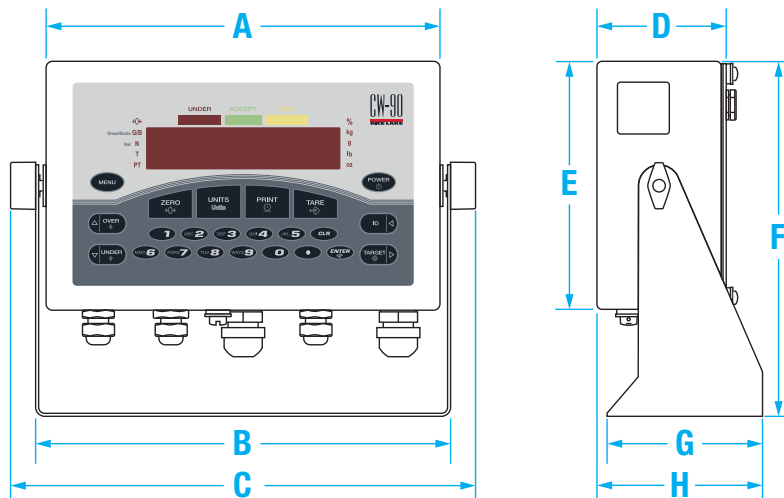

# CW-90

Checkweigh Indicator

## Part Number/Price

Part #	Description	Est. Weight	Price
105970 <sup>†</sup>	CW-90, 115 VAC	7 lb	Consult
105971 <sup>††</sup>	CW-90, 230 VAC, CE marked/OIML approved	7 lb	Consult
118888 <sup>†</sup>	CW-90, 230 VAC	7 lb	Consult
171247 <sup>†††</sup>	CW-90, 230 VAC	7 lb	Consult



<sup>†</sup> US plug (NA) - Type B



<sup>††</sup> Euro Plug - Type E



<sup>†††</sup> IEC Type I plug

## Options/Accessories

Part #	Description	Price
200578	Ethernet TCP/IP, 10 ft cable included	Consult
206272	RS-232/Wi-Fi interface 802.11 A/B	Consult
95357	USB cable, Type A to mini-B, 1 m	Consult
171968	Firmware download cable	Consult
96736	Fiber optic board	Consult
78026	Fiber optic, duplex cable 100 ft	Consult
80892	Fiber optic cutter	Consult
117358	WeighVault <sup>®</sup> (requires part number 77142 or 206272)	Consult

*To have your option factory installed, please specify when placing your order.*

INDICATORS /  
CONTROLLERS



## Specifications

### Power:

Line voltages: 115 to 230 VAC  
Frequency: 50/60 Hz

### Power Consumption:

1.5 A at 115 VAC (8 W)  
0.75 A at 230 VAC (8 W)

### Excitation Voltage:

+5 VDC 8 × 350 ohm or 16 × 700 ohm load cells

### Analog Signal Input Range:

-0.5 mV/V to 4.5 mV/V

### Analog Signal Sensitivity:

0.3 uV/graduation minimum  
1.5 uV/graduation recommended

### A/D Sample Rate:

7.5 to 960 Hz software selectable

### Resolution:

Display: 100,000 counts

### System Linearity:

± 0.01% full scale

### Digital I/O:

Four channels on CPU board

### Circuit Protection:

RFI, EMI, ESD protection

### Annunciators:

Designators for percent, kg, gm, lb, oz, center of zero, G/B, N, T, PT, neg, motion

### Display:

Large 0.8 in 14-segment, six-digit high-intensity red LED display

### Keys/Buttons:

Piezo keypad, 11 keys with international symbols

### Temperature Range:

Certified: 14 °F to 104 °F (-10 °C to 40 °C)

### Rating/Material:

IP69K, 304 stainless steel

### Warranty:

Three-year limited

### Approvals:

NTEP CC 08-092, Class III/IIIL 10,000d  
Measurement Canada AM-5710  
OIML R76/2006-GBI-10.02  
T C 11569  
cULus Listed  
CE Marked

## Approvals



## Dimensions

A	9.5 in (241 mm)
B	10.02 in (255 mm)
C	11.24 in (285 mm)
D	3.12 in (79 mm)
E	6.00 in (152 mm)
F	8.57 in (218 mm)
G	3.75 in (95 mm)
H	4.00 in (102 mm)

## Standard Features

- PreVent™ breather vent
- Storage for up to 50 IDs
- Unit of measure: kg, gm, lb, oz, lb/oz
- LED display
- Two full duplex serial ports
- Configurable print formats
- Audit trail tracking
- Optional communications: Ethernet, USB or fiber optic
- Four configurable digital I/O
- Reflash memory to upgrade firmware
- Auto print capability
- Battery backed up time and date
- Accumulator
- Piezo keypad consisting of zero, units, print, tare, over, under, ID, target, enter, menu, power

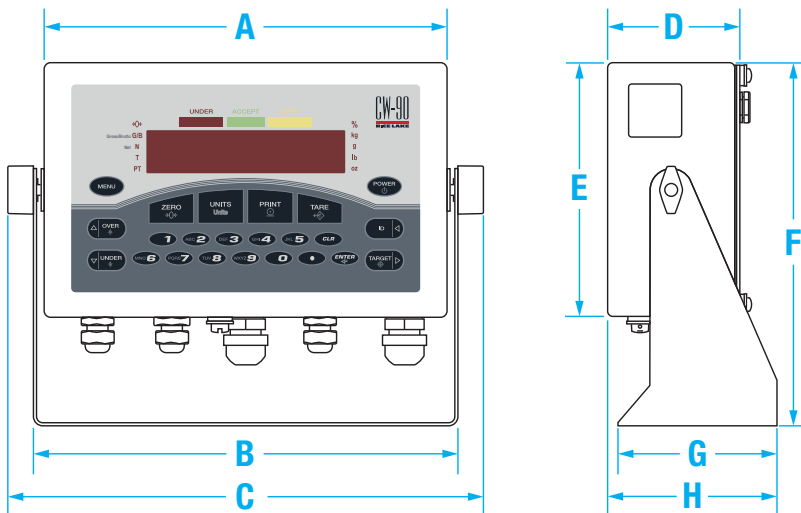

# CW-90X

Checkweigh Indicator

## Part Number/Price

Part #	Description	Est. Weight	Price
105972 <sup>†</sup>	CW-90X, 115 VAC	7 lb	Consult
105973 <sup>††</sup>	CW-90X, 230 VAC, CE marked/OIML approved	7 lb	Consult
118889 <sup>†</sup>	CW-90X, 230 VAC	7 lb	Consult
171248 <sup>†††</sup>	CW-90X, 230 VAC	7 lb	Consult



<sup>†</sup> US plug (NA) - Type B



<sup>††</sup> Euro Plug - Type E



<sup>†††</sup> IEC Type I plug

## Options/Accessories

Part #	Description	Price
200578	Ethernet TCP/IP, 10 ft cable included	Consult
206272	RS-232/Wi-Fi interface 802.11 A/B	Consult
95357	USB cable, Type A to mini-B, 1 m	Consult
171968	Firmware download cable	Consult
96736	Fiber optic board	Consult
78026	Fiber optic, duplex cable 100 ft	Consult
80892	Fiber optic cutter	Consult
117358	WeighVault™ (requires part number 77142 or 206272)	Consult

*To have your option factory installed, please specify when placing your order.*

INDICATORS /  
CONTROLLERS